

WIRING DIAGRAMS

Article Text

1991 Toyota MR2

For Electronics & Computers El Camino Real Santa Clara CA 95051

Copyright © 1997 Mitchell International

Wednesday, November 25, 1998 12:12PM

ARTICLE BEGINNING

1991 WIRING DIAGRAMS

Toyota

MR2

COMPONENT LOCATION MENU

COMPONENT LOCATIONS TABLE

Component	Figure No. (Location)
A/C AMPLIFIER	6 (B 23)
A/C COMPRESSOR CLUTCH RELAY	7 (A 27)
A/C COND FAN MOTOR	7 (C 24)
A/C CONTROL ASSEMBLY	6 (A-E 20)
A/C DIODE	7 (A 25)
A/C IDLE UP VSV	7 (A 26)
A/T INDICATOR SW/NEUTRAL START SWITCH	9 (C-D 35)
ABS ACTUATOR	5 (A-C 19)
ABS ECU	5 (A 16-19)
AIR INLET SERVO MOTOR	6 (C 23)
AIR VENT MODE CONTROL SERVO MOTOR	6 (D-E 23)
ALTERNATOR	15 (C 56)
AUTO ANTENNA CONTROL RELAY/MOTOR	11 (D-E 40)
BACK-UP LIGHT SW (M/T)	15 (C 59)
BATTERY	1 (A 3)
BLOWER MOTOR	6 (A 23)
BLOWER RESISTOR	6 (A 23)
BUCKLE SWITCH	11 (D 40)
CENTER AIRBAG SENSOR ASSEMBLY	5 (D 19)
CHECK CONN (2.2L A/T)	12 (D-E 47)
CHECK CONN (2.2L A/T)	13 (D-E 51)
CHECK CONN (TURBO)	14 (D-E 55)
CIRCUIT OPENING RLY (2.2L M/T)	13 (A 51)
CIRCUIT OPENING RLY (TURBO)	14 (A 54)
CLOCK	11 (A 43)
CLUTCH START SWITCH (M/T)	15 (B 57)
COLD START INJECTOR	15 (B 57)
COMBINATION SWITCH	8 (B-E 28)
COOLANT TEMP SENSOR	7 (B 25)
COOLING FAN ECU (TURBO)	15 (D 58)
COURTESY LIGHTS	9 (D-E 33-35)
CRUISE CONTROL ACTUATOR	7 (E 27)
CRUISE CONTROL CLUTCH SWITCH	7 (C 26)
CRUISE CONTROL ECU	7 (C-D 27)
CRUISE CONTROL SPEED SENSOR	7 (D 24)
CRUISE CONTROL STOP SWITCH	7 (C 27)
DOOR LOCK ECU	10 (E 37-38)
DUAL PRESSURE SWITCH	7 (B 27)
EFI MAIN RELAY (2.2L A/T)	12 (A 44)

WIRING DIAGRAMS

Article Text (p. 2)

1991 Toyota MR2

For Electronics & Computers El Camino Real Santa Clara CA 95051

Copyright © 1997 Mitchell International

Wednesday, November 25, 1998 12:12PM

EFI MAIN RELAY (2.2L M/T)	13 (A 48)
ELECT IDLE UP DIODE (2.2L A/T)	12 (A 45)
ELECT IDLE UP DIODE (2.2L M/T)	13 (A 48)
ELECT IDLE UP DIODE (TURBO)	14 (B 53)
ENGINE OIL LEVEL ECU (TURBO)	9 (B 35)
FAN RELAYS	7 (A-C 24)
FOG LIGHT SWITCH	8 (E 31)
FUEL PUMP (2.2L A/T)	12 (A 47)
FUEL PUMP (2.2L M/T)	13 (A 51)
FUEL PUMP (TURBO)	14 (A 55)
HAZARD SW	8 (A 28)
HEATER RELAY	7 (A 27)
IGNITER (2.2L A/T)	12 (E 46)
IGNITER (2.2L M/T)	13 (E 50)
IGNITER (TURBO)	14 (E 54)
IGNITION SWITCH	3 (A 11)
ILLUM LIGHTS	5 (D-E 16-17)
INSTRUMENT CLUSTER	9 (A-E 32)
INTERIOR LT CTRL RLY (W/ DOOR KEY CYL LT)	9 (E 35)
INTERIOR LT CTRL RLY (W/O DOOR KEY CYL LT)	9 (D 35)
J1 JUNCTION CONN	11 (B-C 43)
J2 JUNCTION CONN	5 (D 16)
J3 JUNCTION CONN	8 (E 28)
JUNCTION BLOCK #3 (J/B #3)	4 (C-D 12-15)
KEY INTERLOCK SOLENOID	7 (E 25)
LEFT DOOR COURTESY SWITCH	10 (C 36)
LEFT DOOR LOCK MOTOR	10 (D 36)
MAIN FUS LINK	1 (A 3)
O/D MAIN SW	9 (D 33)
POWER MAIN RELAY	11 (A 40)
POWER STEERING ECU	3 (E 9-10)
POWER STEERING RELAY	2 (E 8)
POWER WINDOW MASTER SWITCH	11 (A-B 40)
REAR LUGGAGE LIGHT	10 (B 38)
RELAY BLOCK #1 (R/B #1)	3 (A-C 8-9)
RELAY BLOCK #2 (R/B #2)	15 (C-E 56)
RELAY BLOCK #5 (R/B #5)	2 (A-C 4-6)
RETRACT CONTROL RELAY (W/ LIGHT RETAINER)	1 (D 3)
RETRACT CONTROL RELAY (W/O LIGHT RETAINER)	1 (B 3)
RHEOSTAT	5 (C 16)
RIGHT DOOR LOCK MOTOR	10 (D 39)
SEAT BELT WARNING RELAY	11 (C 40)
SHIFT LOCK ECU	7 (E 24)
START INJECTOR TIME SWITCH	15 (A 56)
STARTER	15 (A 58)
STARTER RELAY	15 (A 57)
STOP LT SWITCH (W/O CRUISE)	15 (E 57)
TCCS ECU (2.2L A/T)	12 (A-E 44)
TCCS ECU (2.2L M/T)	13 (B-D 48)
TCCS ECU (TURBO)	14 (A-E 52)
THEFT DETERRENT ECU	10 (A 37-38)
THEFT DETERRENT HORN	10 (A 36)
UNLOCK WARN SWITCH	3 (A 11)

WIRING DIAGRAMS

Article Text (p. 3)

1991 Toyota MR2

For Electronics & Computers El Camino Real Santa Clara CA 95051

Copyright © 1997 Mitchell International

Wednesday, November 25, 1998 12:12PM

WIPER MOTOR 8 (B 31)

WIRING DIAGRAMS

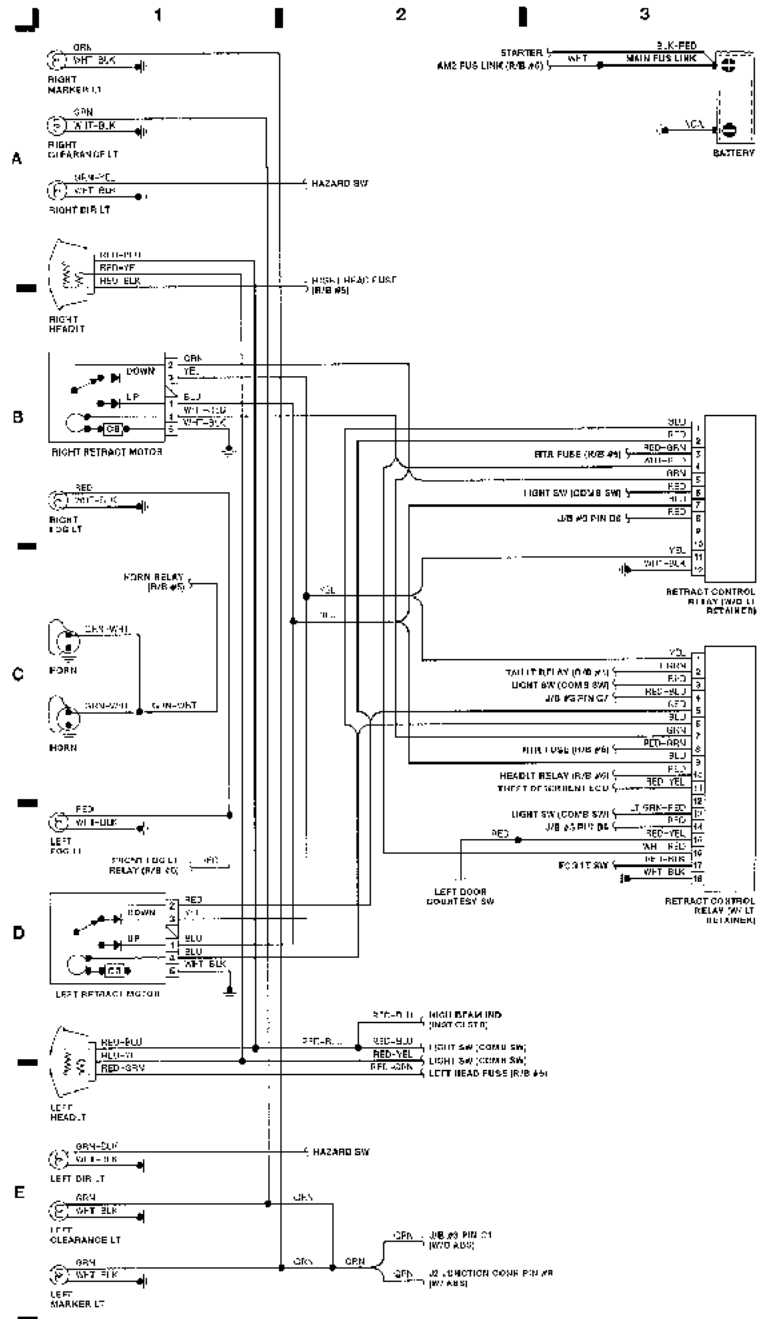

Fig. 1: Engine Compartment & Headlights (Grid 1-3)

WIRING DIAGRAMS

Article Text (p. 4)

1991 Toyota MR2

For Electronics & Computers El Camino Real Santa Clara CA 95051

Copyright © 1997 Mitchell International

Wednesday, November 25, 1998 12:12PM

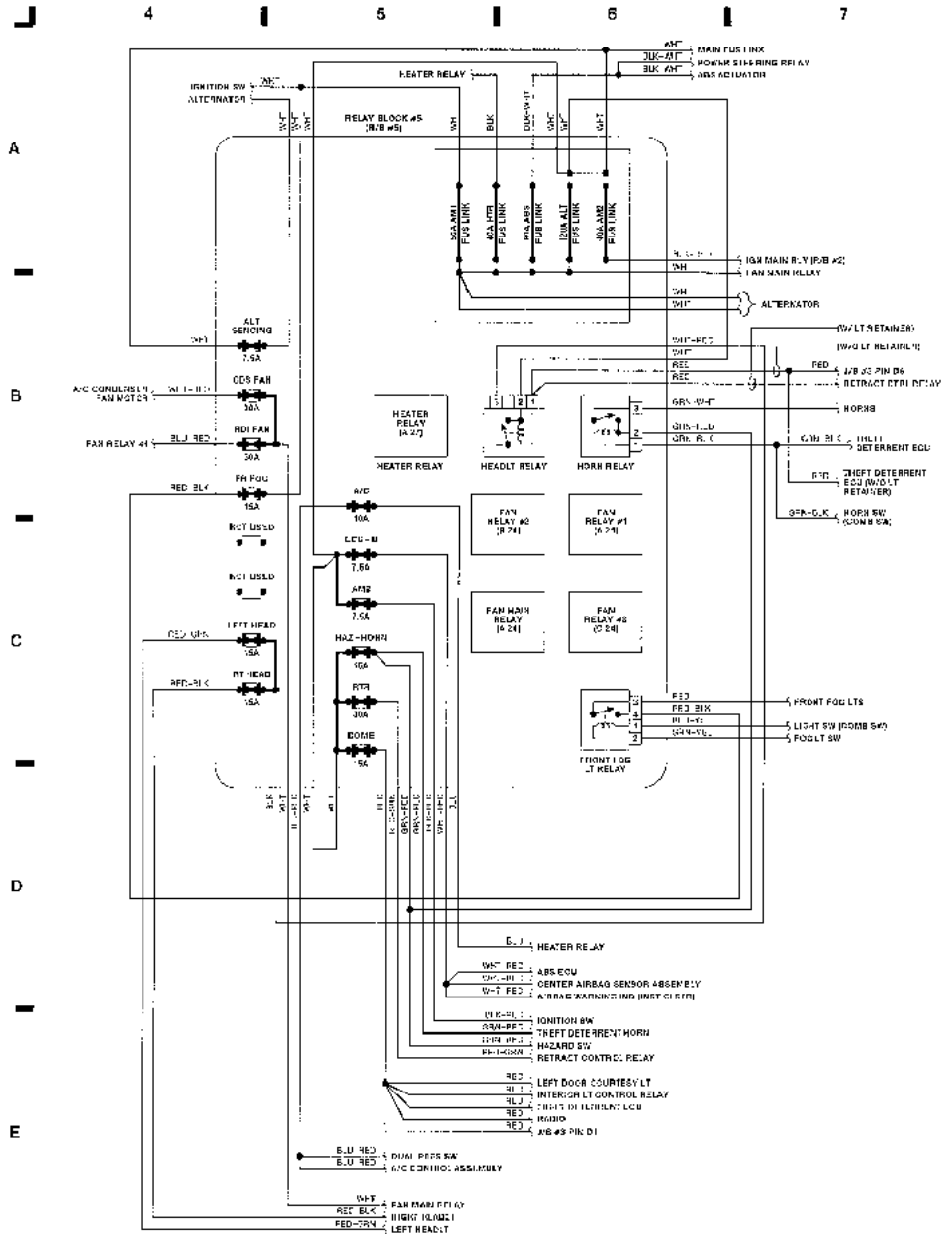

Fig. 2: Relay Block #5 (Grid 4-7)

WIRING DIAGRAMS

Article Text (p. 5)

1991 Toyota MR2

For Electronics & Computers El Camino Real Santa Clara CA 95051

Copyright © 1997 Mitchell International

Wednesday, November 25, 1998 12:12PM

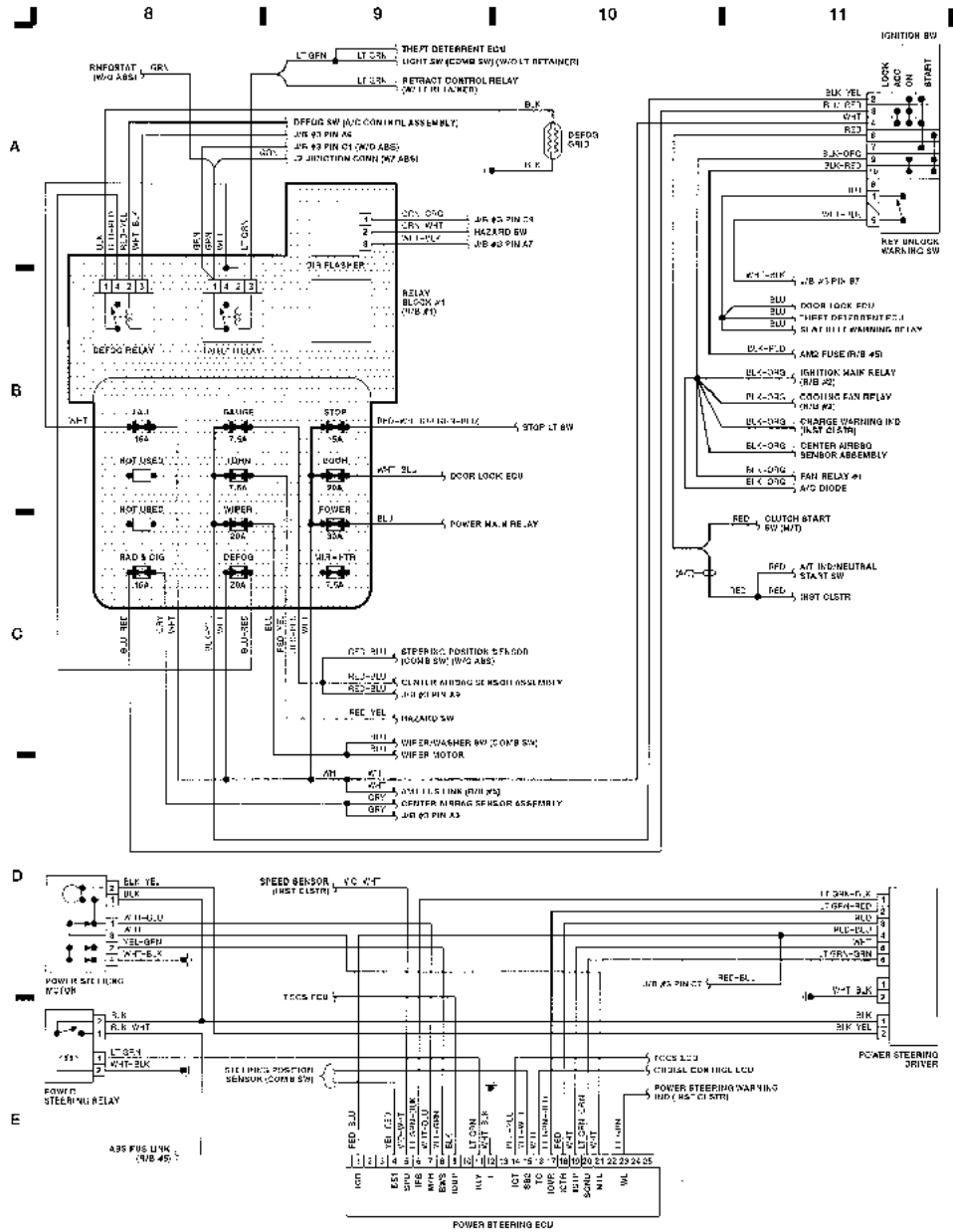

Fig. 3: Relay Block #1, Ignition Sw, Power Steering (Grid 8-11)

WIRING DIAGRAMS

Article Text (p. 7)

1991 Toyota MR2

For Electronics & Computers El Camino Real Santa Clara CA 95051

Copyright © 1997 Mitchell International

Wednesday, November 25, 1998 12:12PM

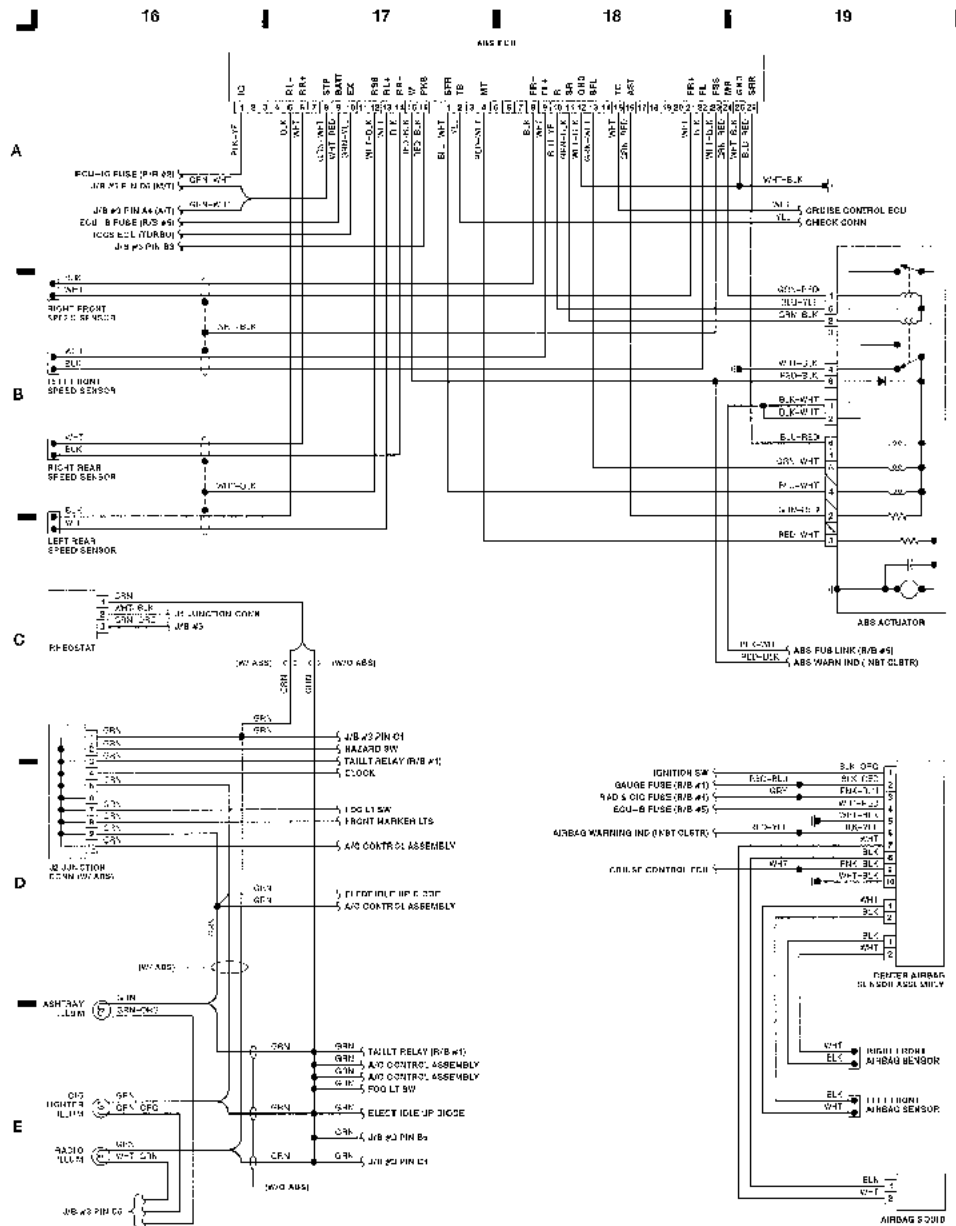

Fig. 5: ABS ECU, Airbag, J2 Junction Conn (Grid 16-19)

WIRING DIAGRAMS

Article Text (p. 8)

1991 Toyota MR2

For Electronics & Computers El Camino Real Santa Clara CA 95051

Copyright © 1997 Mitchell International

Wednesday, November 25, 1998 12:12PM

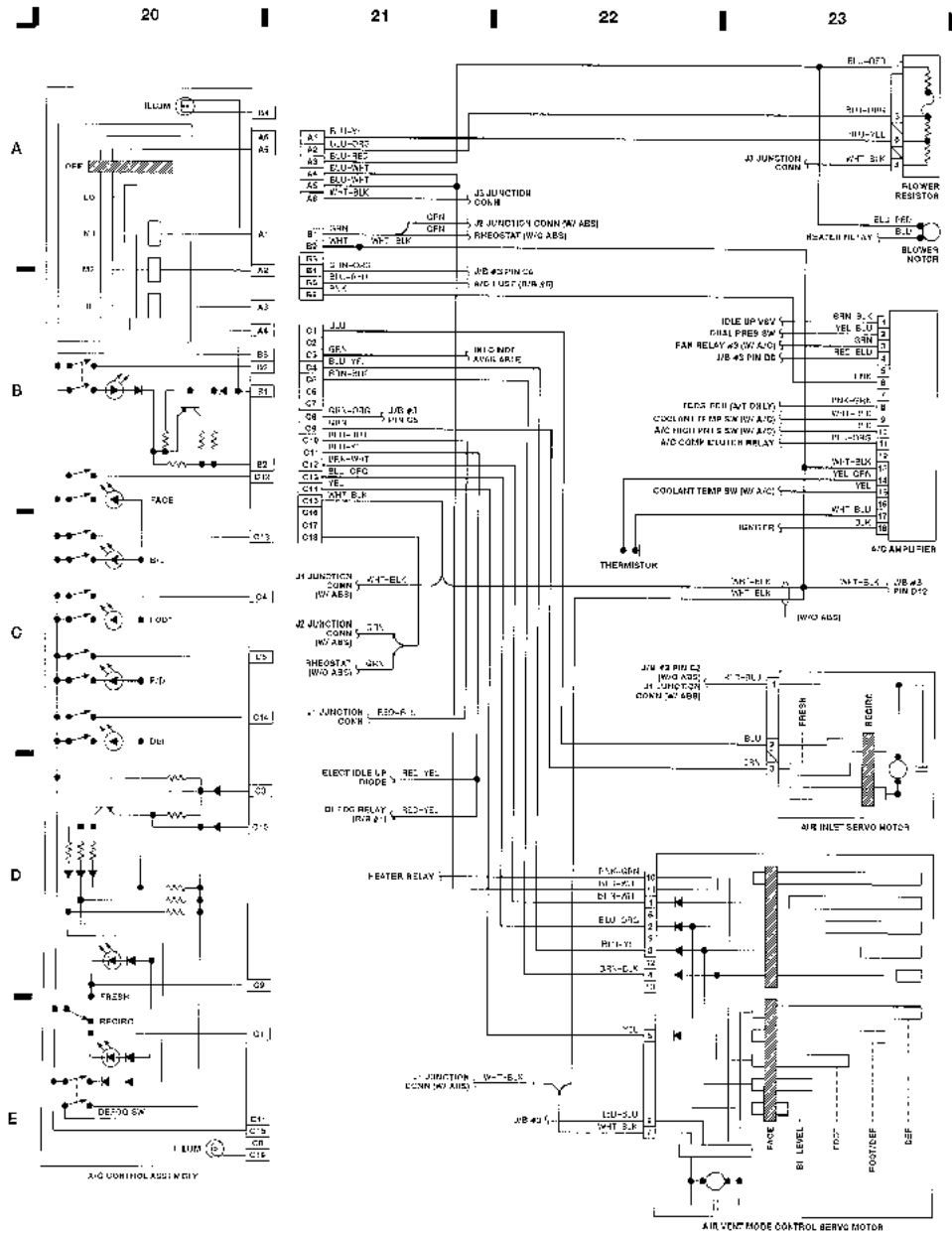

Fig. 6: A/C & Heater (Grid 20-23)

WIRING DIAGRAMS

Article Text (p. 9)

1991 Toyota MR2

For Electronics & Computers El Camino Real Santa Clara CA 95051

Copyright © 1997 Mitchell International

Wednesday, November 25, 1998 12:12PM

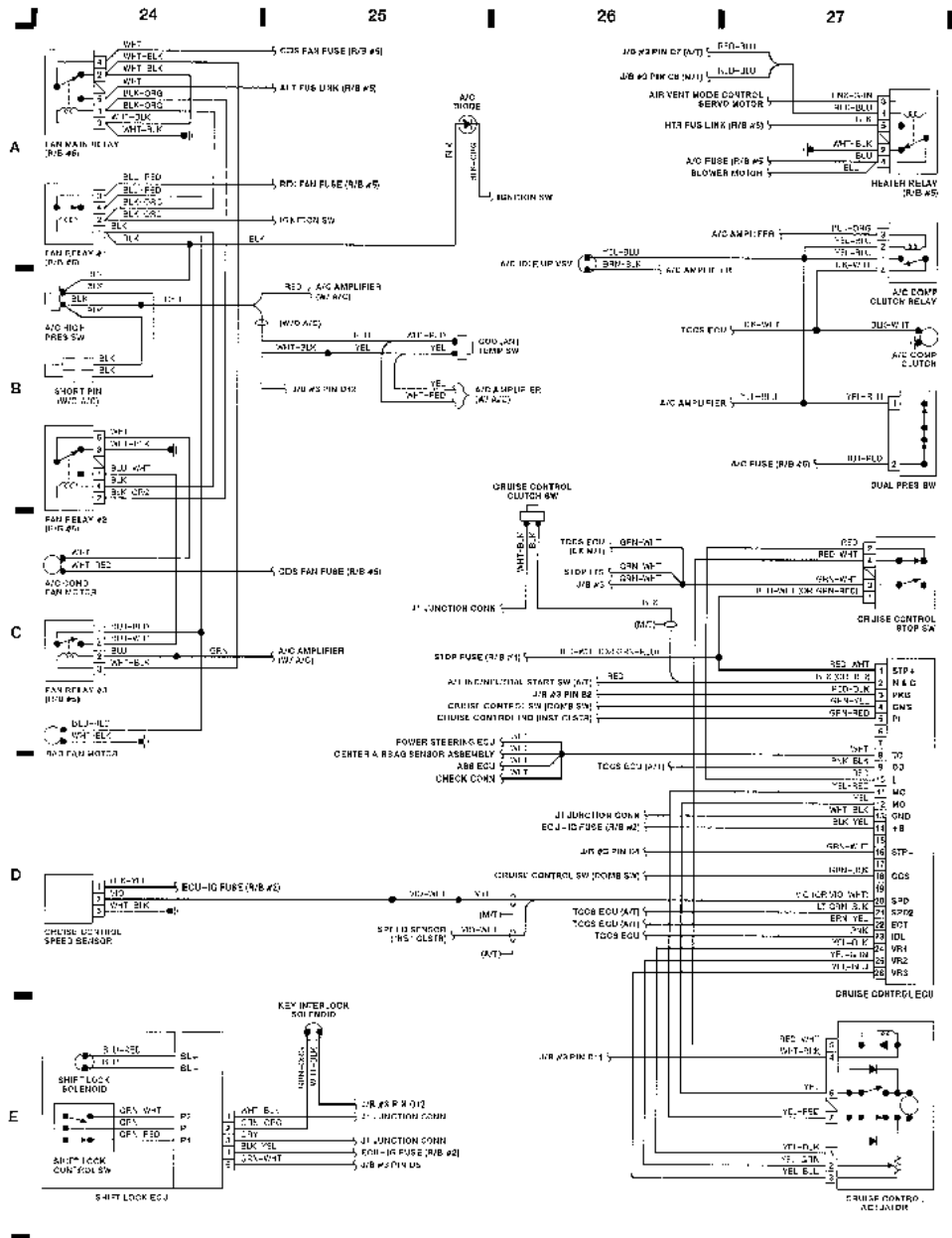

Fig. 7: Cruise Ctrl, Shift lock ECU, A/C (Cont) (Grid 24-27)

WIRING DIAGRAMS

Article Text (p. 10)

1991 Toyota MR2

For Electronics & Computers El Camino Real Santa Clara CA 95051

Copyright © 1997 Mitchell International

Wednesday, November 25, 1998 12:12PM

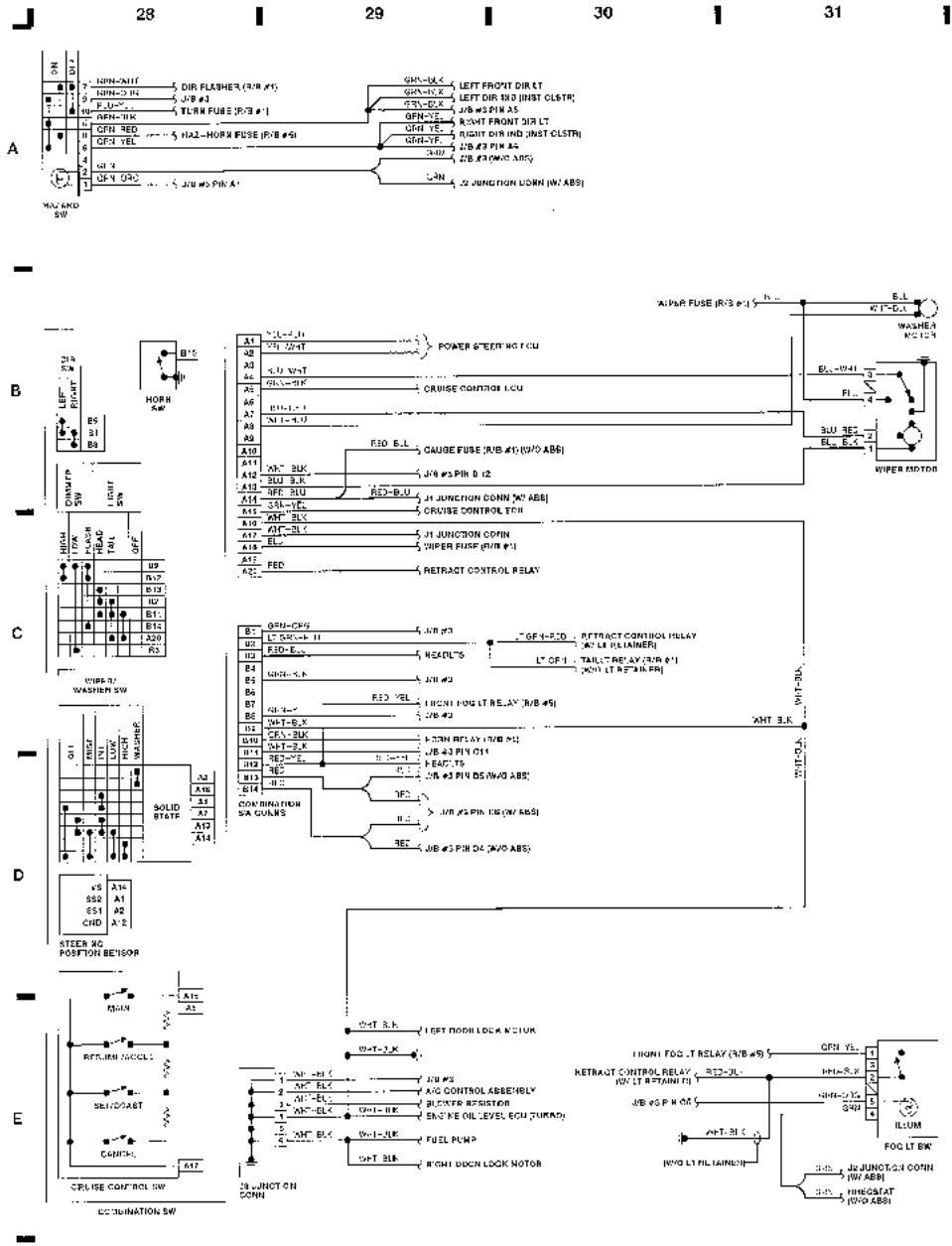

Fig. 8: J3 Junction Conn, Comb Sw, Wiper, Haz Sw (Grid 28-31)

WIRING DIAGRAMS

Article Text (p. 11)

1991 Toyota MR2

For Electronics & Computers El Camino Real Santa Clara CA 95051

Copyright © 1997 Mitchell International

Wednesday, November 25, 1998 12:12PM

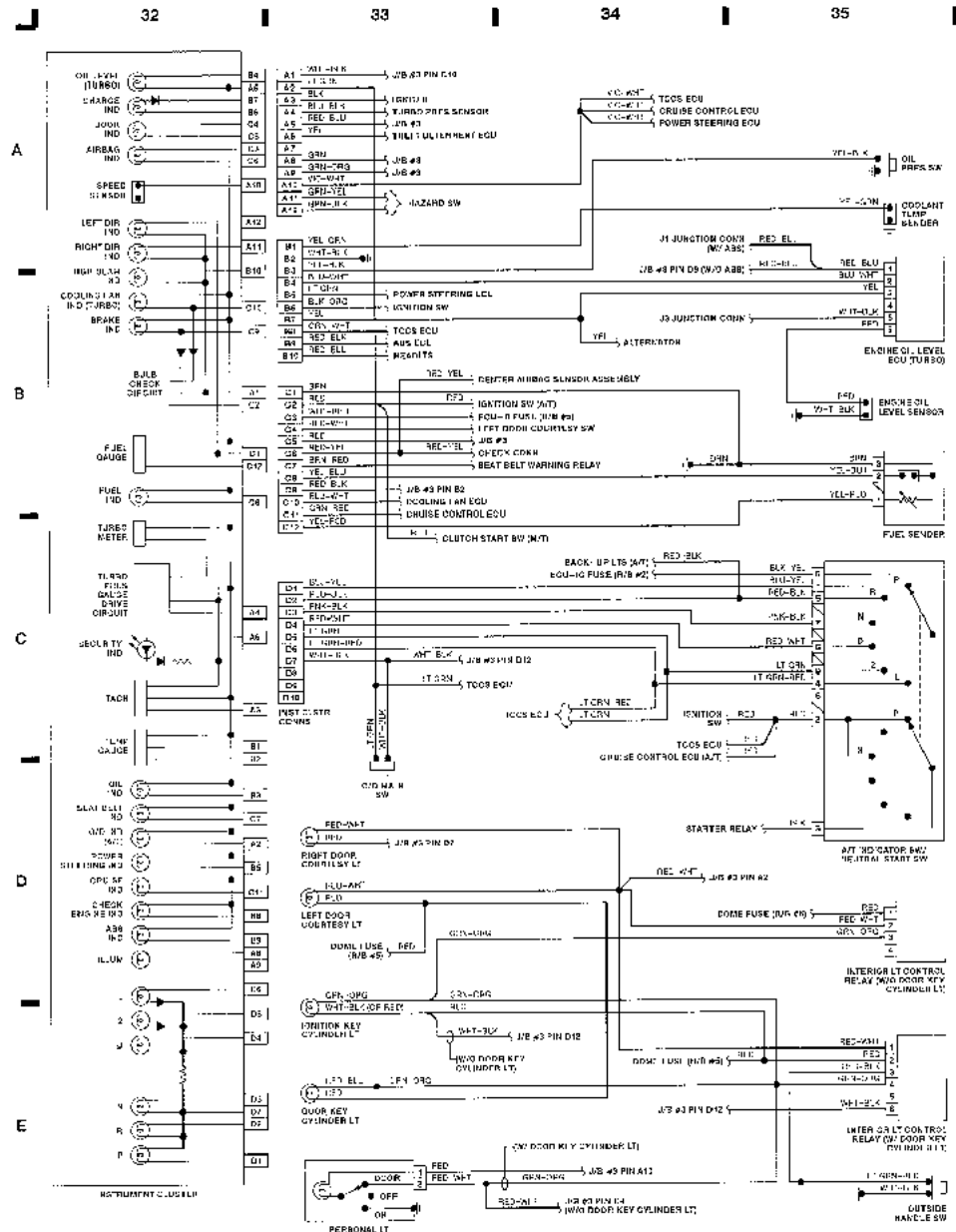

Fig. 9: Inst Cluster, A/T, (Grid 32-35)

WIRING DIAGRAMS
Article Text (p. 12)
 1991 Toyota MR2
 For Electronics & Computers El Camino Real Santa Clara CA 95051
 Copyright © 1997 Mitchell International
 Wednesday, November 25, 1998 12:12PM

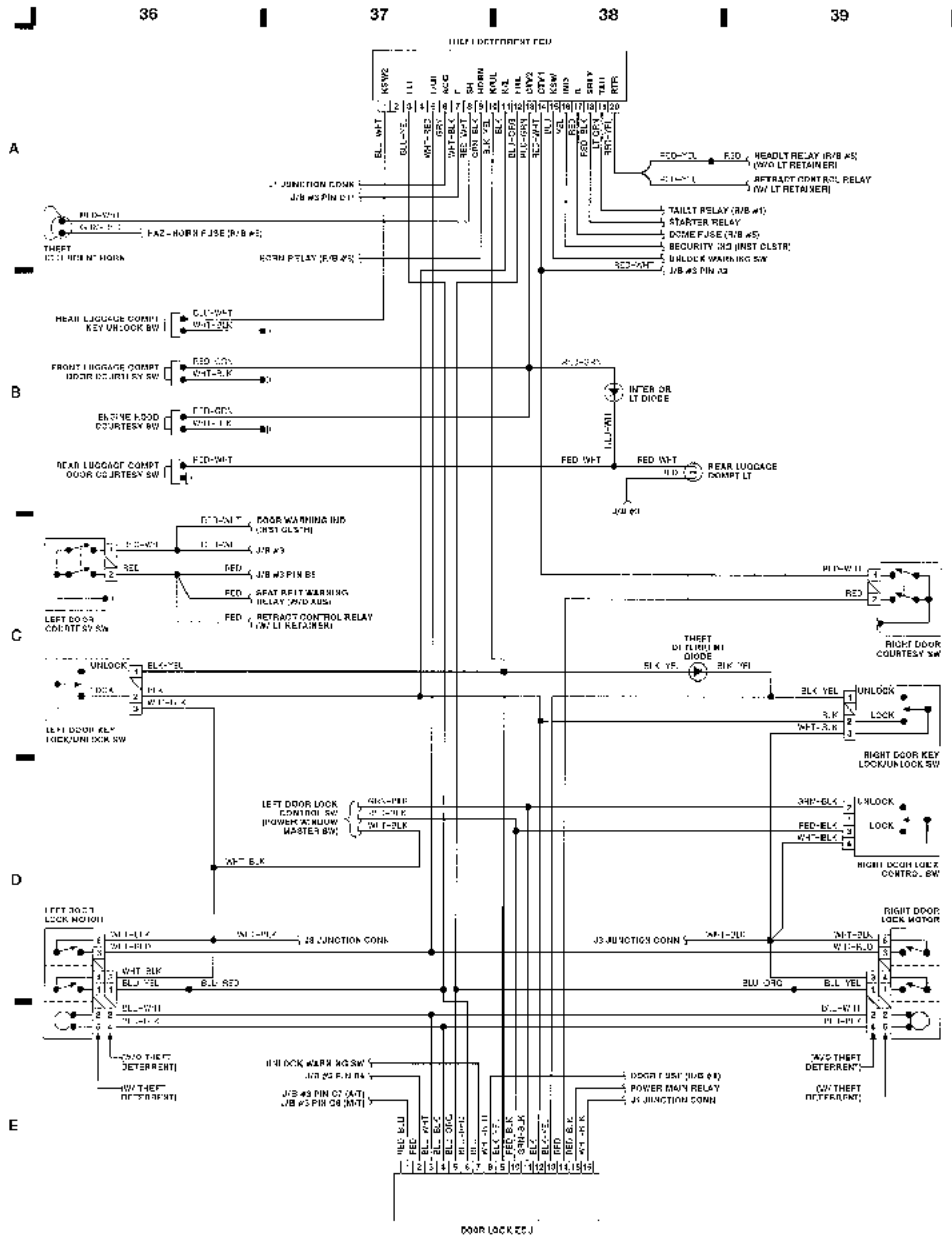

Fig. 10: Power Doors, Theft Deterrent (Grid 36-39)

WIRING DIAGRAMS

Article Text (p. 13)

1991 Toyota MR2

For Electronics & Computers El Camino Real Santa Clara CA 95051

Copyright © 1997 Mitchell International

Wednesday, November 25, 1998 12:12PM

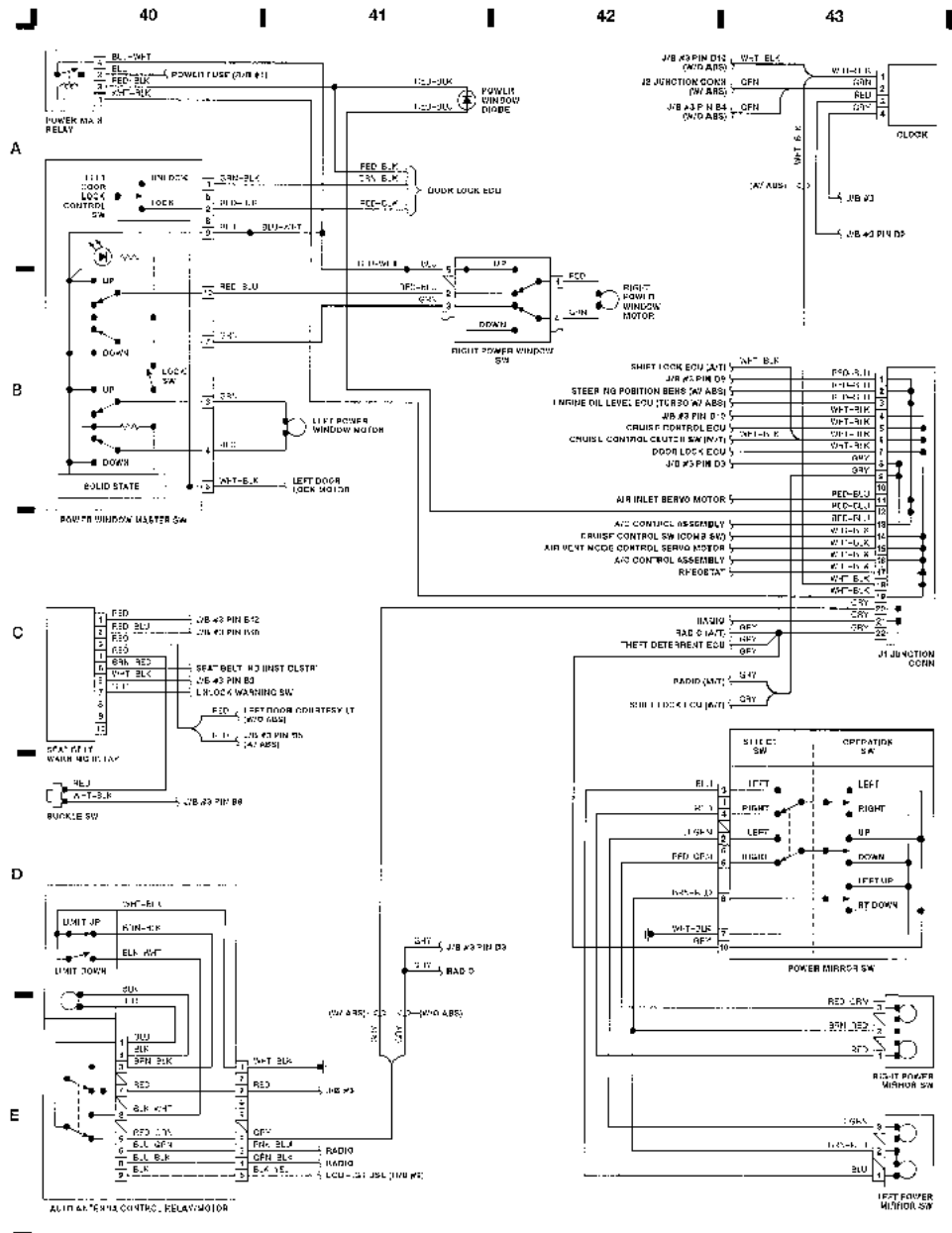

Fig. 11: J1 Junction Conn, Pwr Wdo/Mir, Seat Belt (Grid 40-43)

WIRING DIAGRAMS

Article Text (p. 14)

1991 Toyota MR2

For Electronics & Computers El Camino Real Santa Clara CA 95051

Copyright © 1997 Mitchell International

Wednesday, November 25, 1998 12:12PM

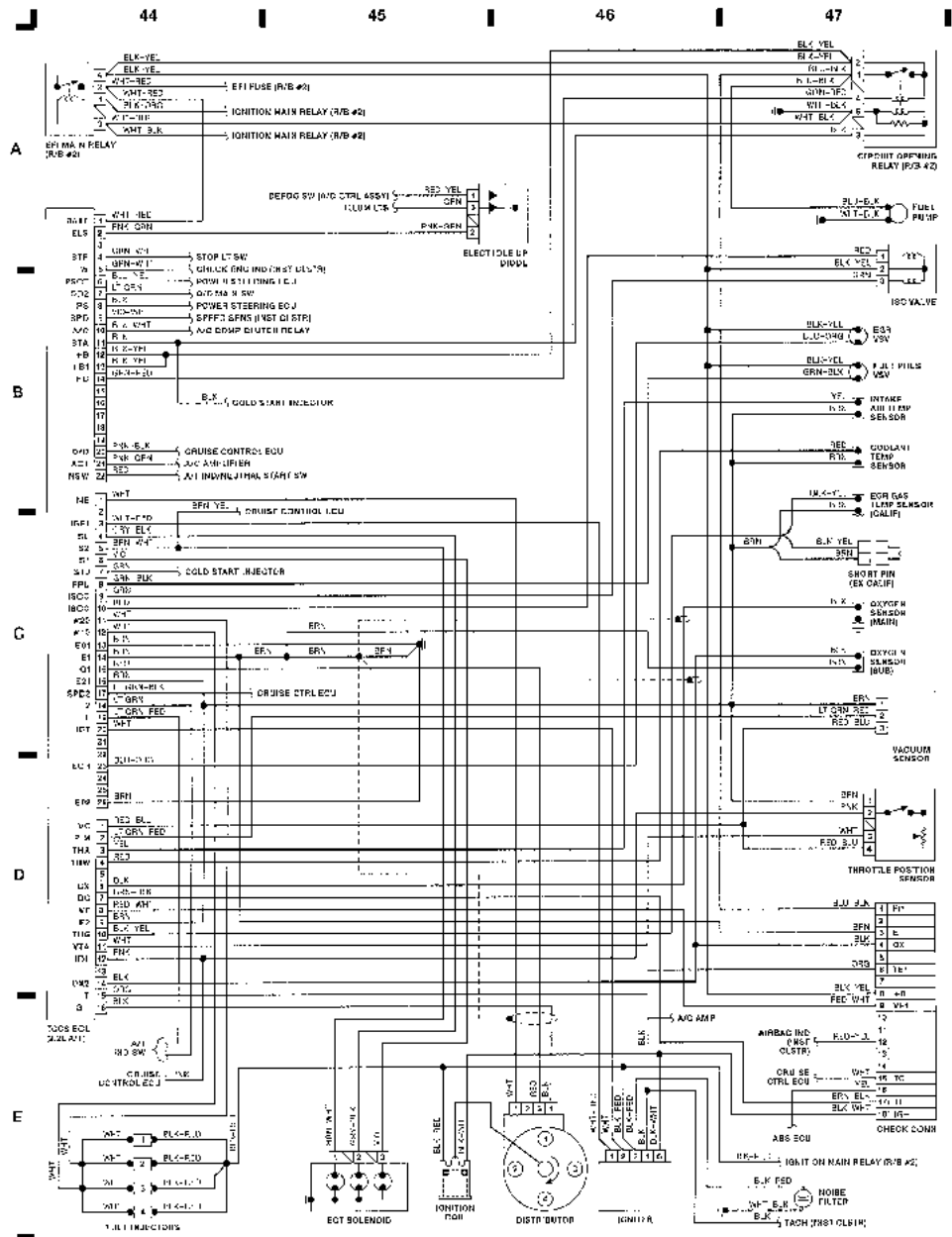

Fig. 12: Computer Engine Control (2.2L A/T) (Grid 44-47)

WIRING DIAGRAMS

Article Text (p. 15)

1991 Toyota MR2

For Electronics & Computers El Camino Real Santa Clara CA 95051

Copyright © 1997 Mitchell International

Wednesday, November 25, 1998 12:12PM

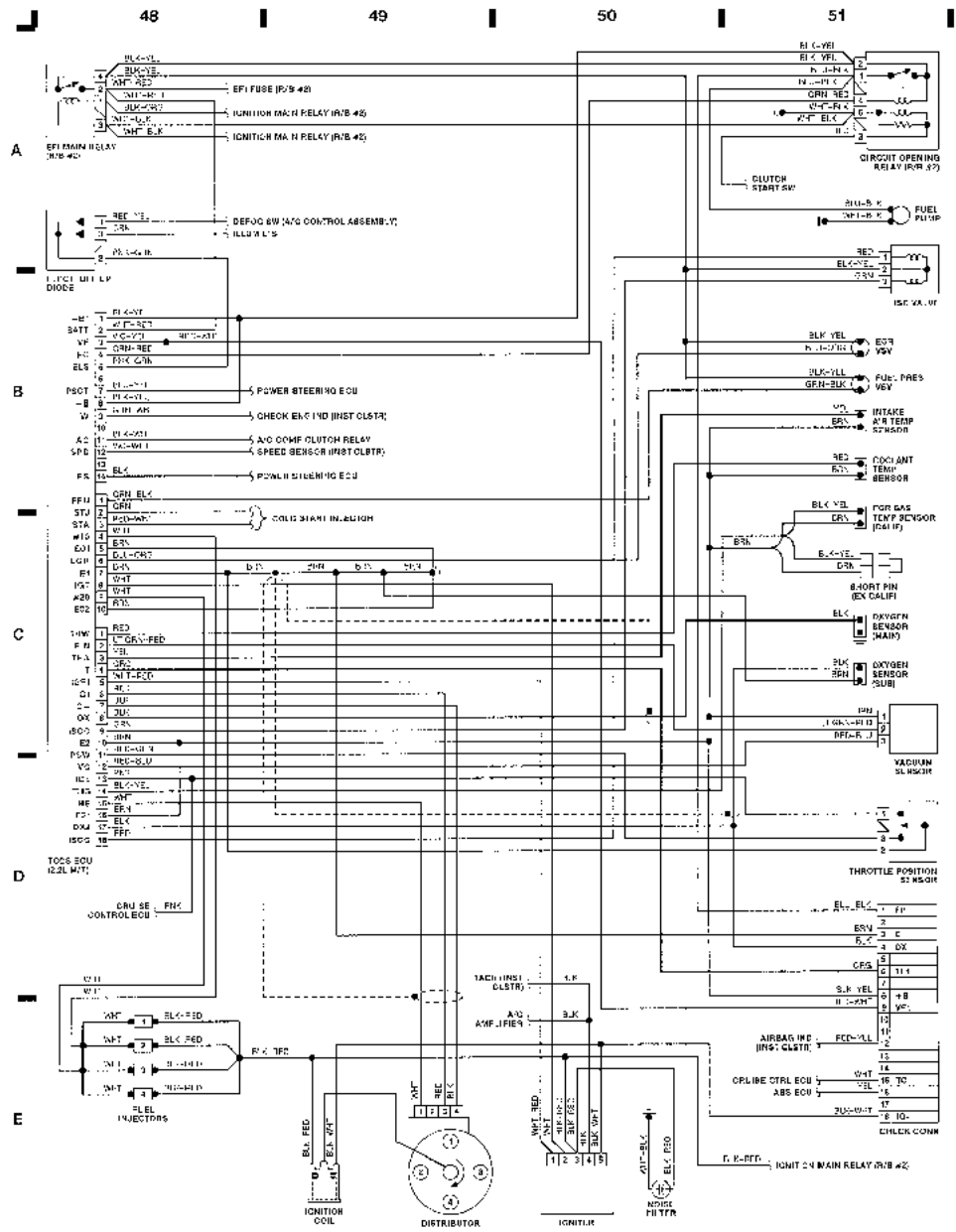

Fig. 13: Computer Engine Control (2.2L M/T) (Grid 48-51)

WIRING DIAGRAMS

Article Text (p. 16)

1991 Toyota MR2

For Electronics & Computers El Camino Real Santa Clara CA 95051

Copyright © 1997 Mitchell International

Wednesday, November 25, 1998 12:12PM

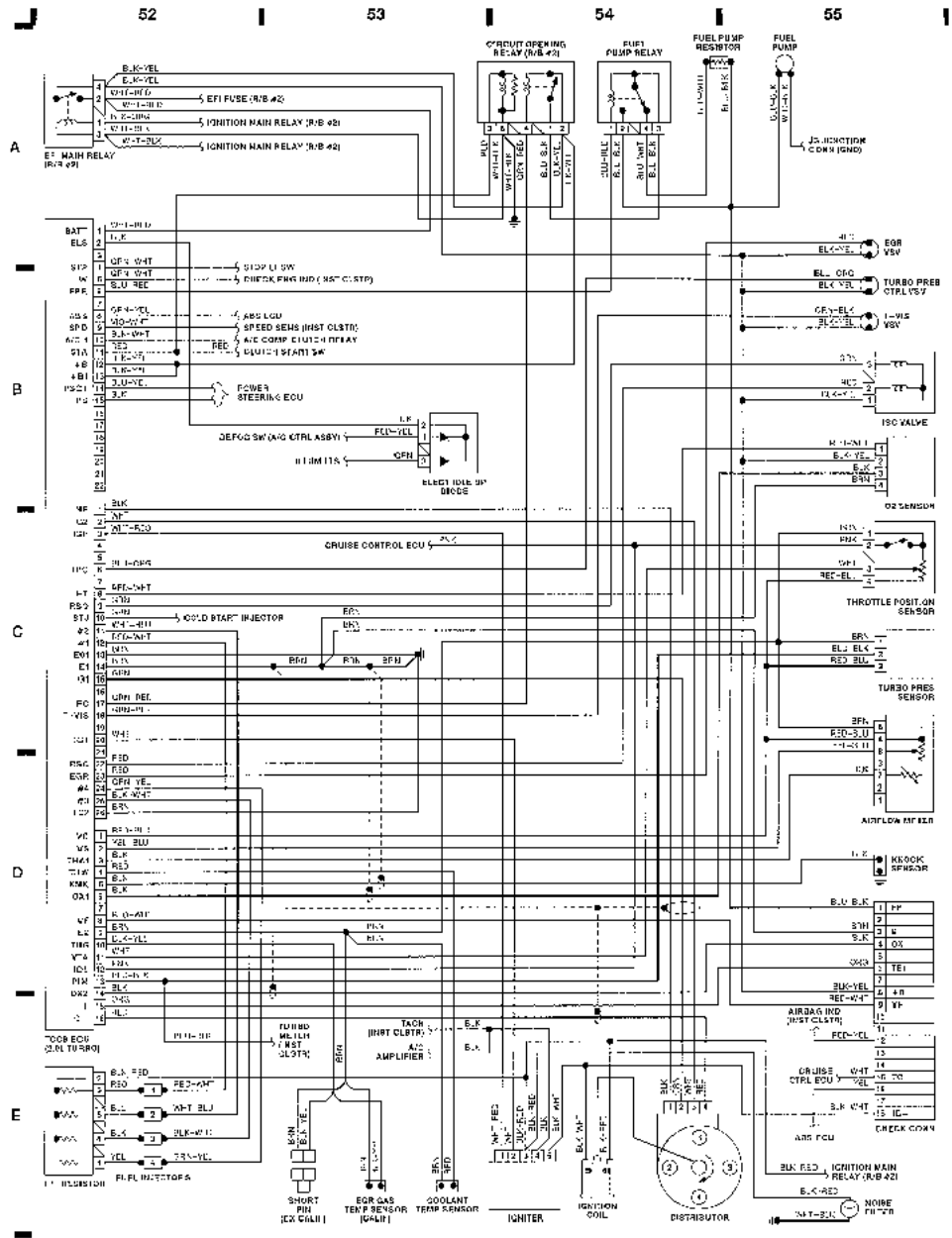

Fig. 14: Computer Engine Control (2.0L Turbo) (Grid 52-55)

WIRING DIAGRAMS

Article Text (p. 17)

1991 Toyota MR2

For Electronics & Computers El Camino Real Santa Clara CA 95051

Copyright © 1997 Mitchell International

Wednesday, November 25, 1998 12:12PM

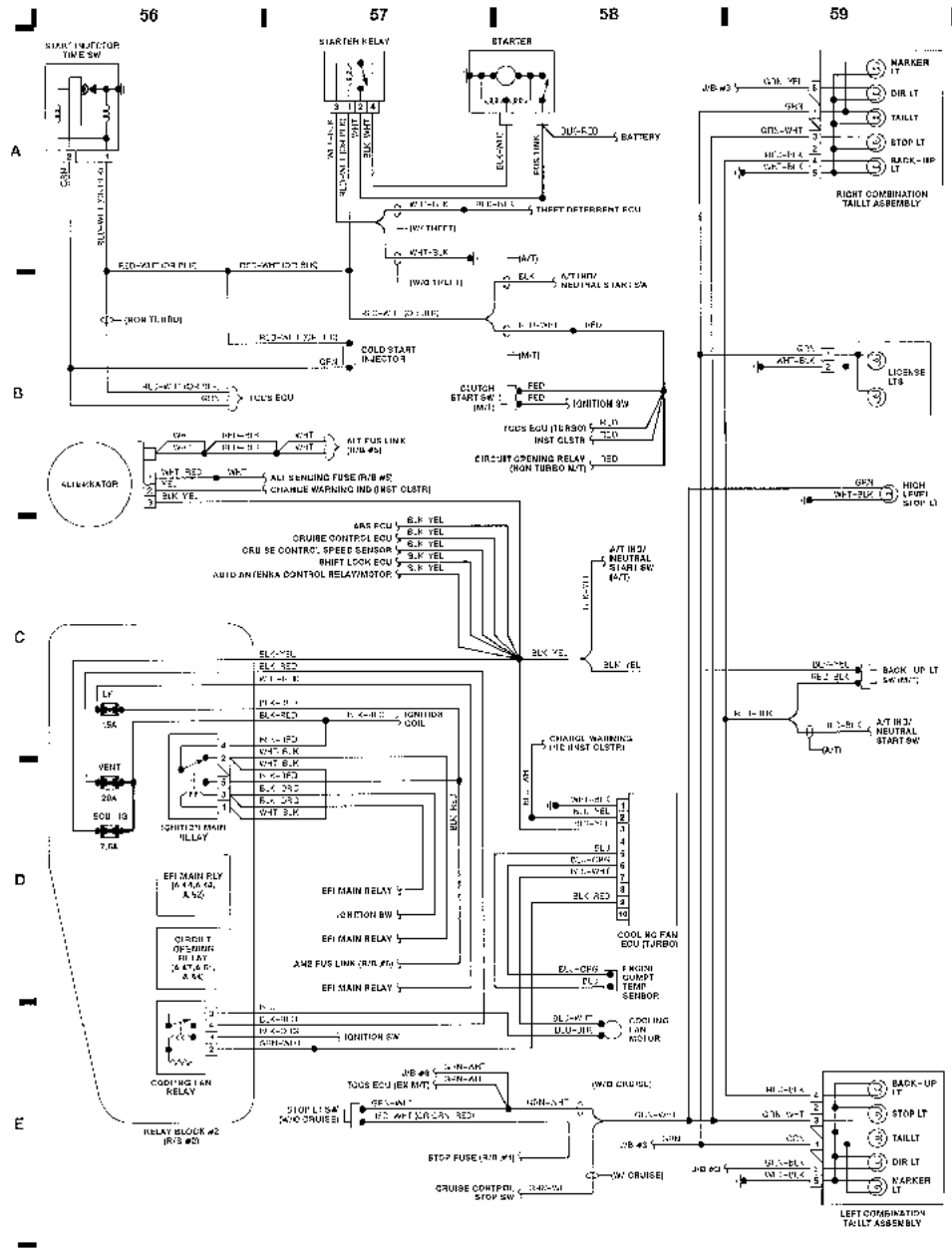

Fig. 15: Relay Block #2, Starter, Tailights (Grid 56-59)

END OF ARTICLE